

NEXUS

RECYCLING MANAGEMENT SYSTEM

www.nexusrecycle.com



The machine waits until a customer approaches and enters a pin number.



The pin number is validated, the customer is confirmed and the customer signs their name on the signature pad to accept payment. The camera at the top of the unit captures a picture of the customers face.



Money is counted from a collection of known available bills and coins. If a bill or coin runs out, the system will use other bills/coins to fulfill the request.



A visual aid is shown on screen representing the bills and coins that were dispensed to the customer.



The machine resets and is ready for the next customer.



Should anything abnormal occur, the machine will lock itself and make it known it is not working. It will also send a text message to any and all staff which can assist and will offer detailed responses on what occurred (most often, when it is out of money).

NEXUS

RECYCLING MANAGEMENT SYSTEM

www.nexusrecycle.com

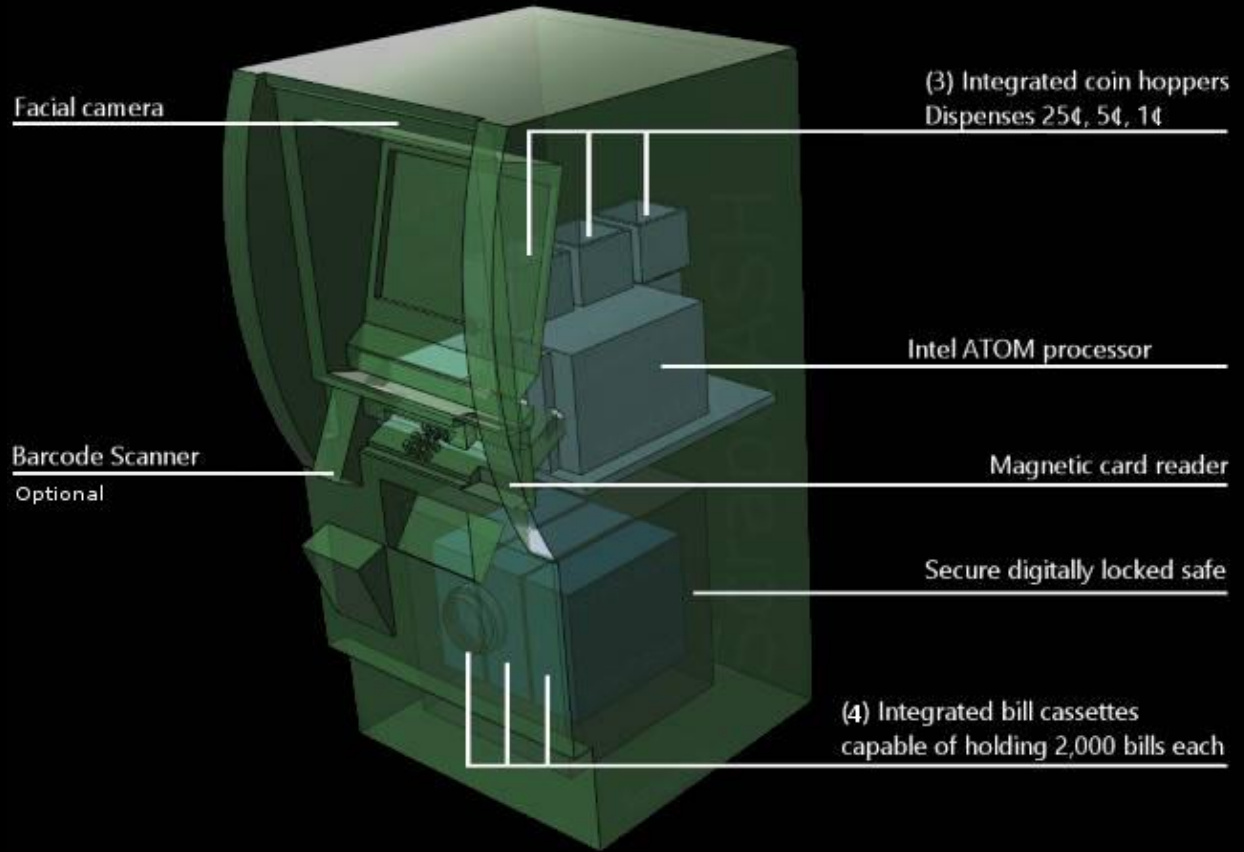

NEXUS

RECYCLING MANAGEMENT SYSTEM

www.nexusrecycle.com

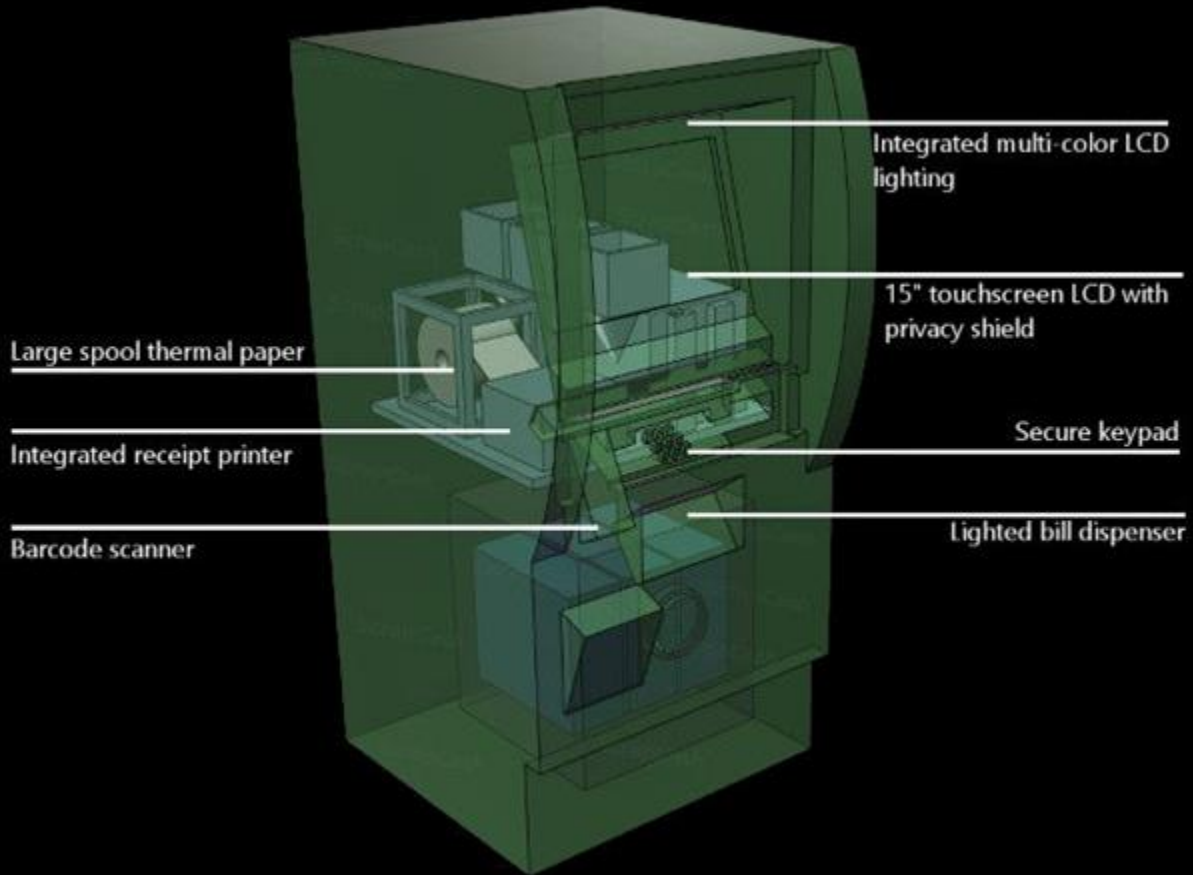

Pricing:

- MEDIUM SECURITY - As pictured: approx. \$23,500 (one time cost).
- HIGH SECURITY – approx. \$26,500 (one time cost) – adds 400lbs (high gauge steel)
- Recurring software costs: \$800 per year (\$66/mo)

Product Dimensions

- Height: 56"
- Width: 18.1"
- Depth: 24.1"

Considerations:

- The unit must not be used in an environment under 45 degrees F or the screen will not function properly.
- The unit should not be used in an environment over 95 degrees F or the life of the electronics may degrade.
- The machine should be stored inside, if possible.
- The machine should be bolted to a concrete pad for safety and security.
- The owner of the machine can refill it at any time, however, in high crime areas it may be recommended to refill the machine using GARDA or BRINKS or another armored car service.

Warranty

- 1 year manufacturer warranty on parts.
- After 1 year, parts may be purchased from the manufacturer.
- Labor to be billed separately to the client. On site technicians are available in nearly every major city.
- Lifetime software warranty and free software support with paid software subscription. See the official LOGIC NINE agreement for terms.

Software

- The machine is equipped with the L9ATM Operating System, an ATM software platform sold, maintained and distributed by LOGIC NINE, LLC.
- Software costs are \$66/mo billed annually on the anniversary of purchase. This rate *includes* text messaging fees and costs as well as internet connected features.
- The ATM features anti-theft security features including the ability to flag/accept/deny suspicious transactions remotely.

Manufacturing and Shipping Times

- Machines are custom built to order and take approx. 2-4 weeks, however, due to global supply chain issues, the time could be much longer.
- Shipping is done by FedEx freight most often and takes about 1-2 weeks for shipping.